



**ALUTEC KK**

# ***Ocelový trubkový konstrukční systém***

Flexibilní řešení pro vytvoření  
individuálních sestav





## Použití

Trubkový konstrukční systém je využitelný všude tam, kde je zapotřebí s minimálním vybavením rychle vytvořit vlastní konstrukci, avšak není třeba dosahovat extrémní přesnosti sestavy. Systém je vhodný pro výrobu regálů, materiálových a logistických přepravních i stacionárních segmentů a pracovních stolů. Zároveň je vhodný pro konstrukce celků, která jsou definována jako antistatické ESD s požadavkem odvádění elektrostatického náboje.

## Příslušenství

Systém je navržen s širokou škálou příslušenství a spojovacích prvků, které umožňují vytvořit prakticky libovolné tvarové spojení trubek a zároveň umožňují konstrukci kombinovat s klasickým profilovým konstrukčním systémem. Mezi klíčové spojovací prvky patří adaptéry a různé druhy spojek (např. oboustranné, úhlové, kloubové), společně se záslepkami, závitovými vložkami a držáky válečkových lišt.



## Základní parametry

kruhový profil	<b>28 a 28,6 mm</b>
ocelová trubka o tloušťce	<b>1; 1,5; 2 mm</b>
poplastovaná; ESD; nerez - tl. stěny	<b>1; 2 mm</b>

## PODROBNÝ POPIS POTAŽENÝCH TRUBEK - Ø = 28 mm



### Název produktu

CP-28T	potažená trubka
CP-28T-ESD	ESD potažená trubka
SPS-28T	nerezová trubka
PCP-28T	trubka s práškovým nástřikem

T = 1,0mm 1,5mm 2,0mm

## STANDARDNÍ BARVY POTAŽENÝCH TRUBEK Ø = 28 mm



	IV : Ivory
	WH : White
	SB : Sky Blue
	DB : Dark Blue
	RE : Red
	GR : Green
	YE : Yellow
	BE : Beige
	LG : Lite Gray
	DG : Dark Gray
	BK : Black
	EBK : ESD Black
	ESD Gray
	ESD Ivory

### T = tloušťka

07 = T0,7
10 = T1,0
15 = T1,5
20 = T2,0

**POTAŽENÉ TRUBKY - Ø = 28 mm**

číslo dílu	rozměr	hmotnost	kapacita	MOQ	zařazení	standardní délka	barva	obrázek
	(mm)	(g/m)	kg/m	(ks)		(mm)		
CP-2807	Ø 28 * 0,7	505	45	⊙	potažená trubka	4000	IV (ESD) WH SB DB RE GR (ESD) YE BE LG BK	
CP-2810	Ø 28 * 1,0	700	100	⊙				
CP-2815	Ø 28 * 1,5	1000	150	1000				
CP-2820	Ø 28 * 2,0	1300	200	500				
CP-2807ESD	Ø 28 * 0,7	505	45	⊙	potažená trubka	4000	EBK ESD šedá	
CP-2810ESD	Ø 28 * 1,0	700	100	⊙				
CP-2815ESD	Ø 28 * 1,5	1000	150	1000				
CP-2820ESD	Ø 28 * 2,0	1300	200	500				
PCP-2810	Ø 28 * 1,0	600		⊙	trubka s práškovým nástríkem	4000	všechny barvy	
PCP-2820	Ø 28 * 2,0	1300		⊙				
SPS-2810	Ø 28 * 1,0	670	90	500	SUS439 SUS201 SUS304 nerez	4000	stříbrná	
SPS-2812	Ø 28 * 1,2	780	110	750				

## VLASTNOSTI TRUBKEK D-COAT-ECO-PIPE

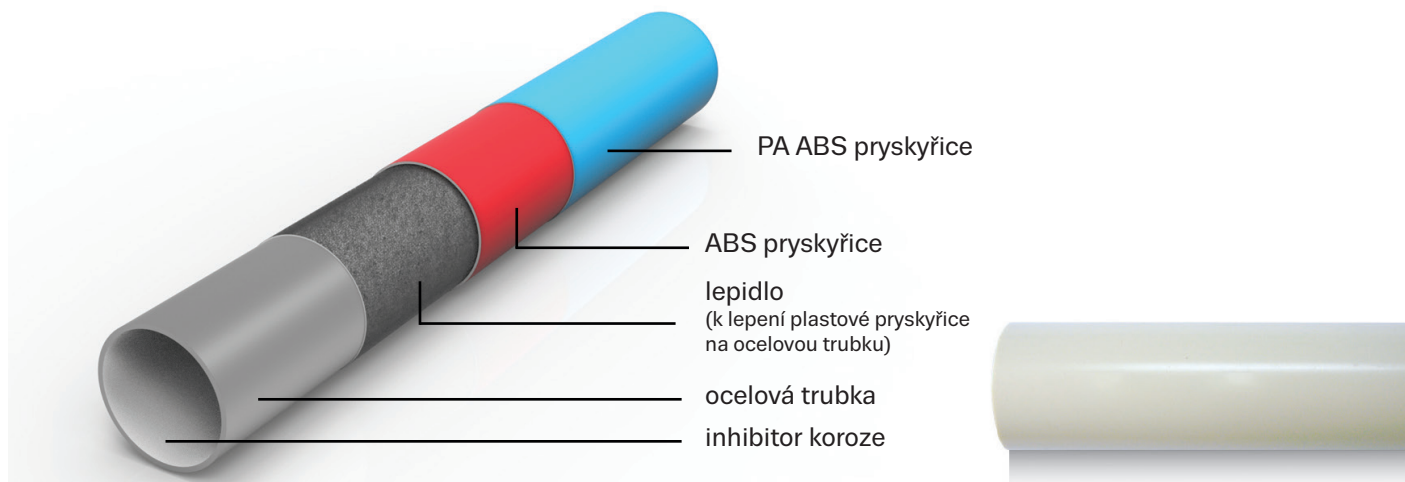

1. Ocelová trubka je potažena ABS. Poté je povrch opět potažen novým materiálem PA ABS.
2. Trubka D-coat, ve srovnání s konvenční trubkou s ABS povlakem, má vynikající odolnost vůči oleji a chemikáliím.  
Zejména solím, oleji a proti korozi, nebo řeznému oleji nezpůsobujícímu praskliny, nebo změnu barvy potrubí.
3. Tento produkt je dodáván v různých barvách pro použití v různých variacích, nebo podle firemních barev společnosti
4. Díky vynikající odolnosti se tato trubka snadno zpracovává. Protikorozní povlak uvnitř trubky poskytuje vynikající odolnost proti korozi.



### 1. Ekologický

ECO-pipe je kompletně recyklovatelná práškově lakovaná ocelová trubka s vnitřním a vnějším povrchem

### 2. Ekonomický

- 20% méně než potažená trubka
- 35% méně než ESD potažená trubka
- 35% méně než ocelová trubka

### 3. Barevnost

Širší výběr barev a textur.

### 4. Chemická odolnost

Vysoká odolnost vůči oleji, UV záření a korozi.

### 5. Nehořlavý

Žádné emise toxických výparů při požáru.

### 6. Bez elektrolytické koroze

Bez elektrolytické koroze.

## VÝHODY NEREZOVÉ TRUBKY

### 1. Environmentální

Nerezová trubka, která je 100% recyklovatelná

### 2. Vysoká pevnost a odolnost

Povrch odolný proti lehkému otěru nebo kontaktu s kovovými nástroji

### 3. Vysoká olejová a chemická odolnost

Vysoká odolnost vůči oleji, rozpouštědlům, bělidlům atd.

### 4. Nehořlavý

Ve své podstatě nehořlavé.

### 5. Vodivé

Inherentně vodivé

ocelová trubka

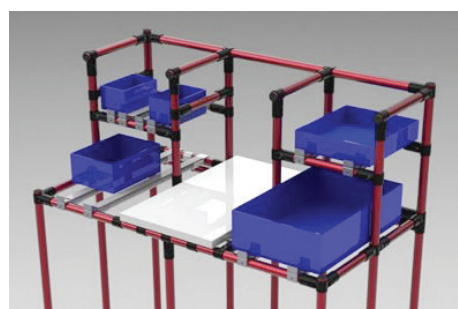
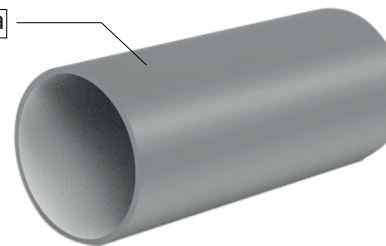







## KOVOVÉ SPOJKY



### BARVY

	Zinek	ZN
	Nikl	NI
	Chrom	CN
	Černá	BK

### DETAILY PRODUKTU

Inovovaný spoj  
s pomocnými  
drážkami pro montáž

boční prolisy ve spojce



dvoudrážkové protiskuzové  
prohloubení

### MATERIÁL

SPCC SUS 304 - ocel

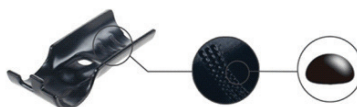



protiskuzová úprava, tři řady  
jemných teček

### TLOUŠŤKA

2,5 mm

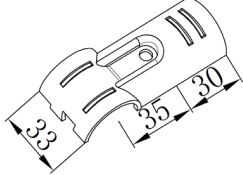
## KOVOVÉ SPOJKY PRO 28 mm TRUBKOVÝ SPOJ

<b>W-1</b>	BARVA: ● BK ● ZN ● CN ● NI
	
Hmotnost: 0,07 kg	
Qty/box: 300 ks	

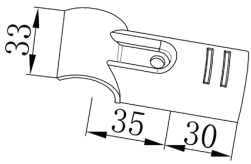
<b>W-1A</b>	BARVA: ● BK ● ZN ● CN ● NI
	
Hmotnost: 0,068 kg	
Qty/box: 300 ks	

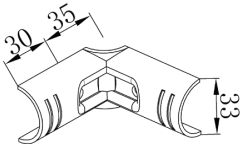
<b>W-2</b>	BARVA: ● BK ● ZN ● CN ● NI
	
Hmotnost: 0,09 kg	
Qty/box: 200 ks	

<b>W-3</b>	BARVA: ● BK ● ZN ● CN ● NI
	
Hmotnost: 0,125 kg	
Qty/box: 100 ks	

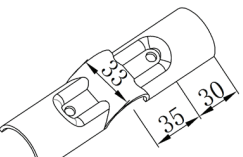
<b>W-4</b>	BARVA: ● BK ● ZN ● CN ● NI
	
Hmotnost: 0,11 kg	
Qty/box: 200 ks	

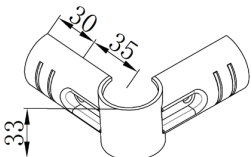
<b>W-3H</b>	BARVA: ● BK ● ZN ● CN ● NI
	
Hmotnost: 0,125 kg	
Qty/box: 100 ks	

<b>W-4A</b>	BARVA: ● BK ● ZN ● CN ● NI
	
Hmotnost: 0,1 kg	
Qty/box: 200 ks	

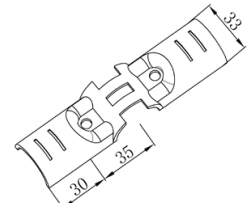
<b>W-4B</b>	BARVA: ● BK ● ZN ● CN ● NI
	
Hmotnost: 0,11 kg	
Qty/box: 200 ks	

<b>W-5</b>	BARVA: ● BK ● ZN ● CN ● NI
	
Hmotnost: 0,055 kg	
Qty/box: 300 ks	

<b>W-6</b>	BARVA: ● BK ● ZN ● CN ● NI
	
Hmotnost: 0,065 kg	
Qty/box: 300 ks	

## KOVOVÉ SPOJKY PRO 28 mm TRUBKOVÝ SPOJ

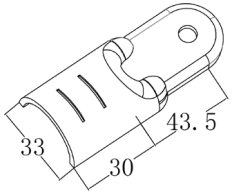
<b>W-6A</b>	BARVA: ● BK ● ZN ● CN ● NI
	
Hmotnost: 0,07 kg	
Qty/box: 300 ks	

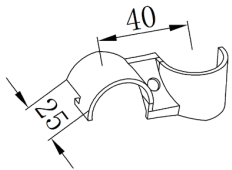
<b>W-7</b>	BARVA: ● BK ● ZN ● CN ● NI
	
Hmotnost: 0,05 kg	
Qty/box: 200 ks	

<b>W-7A</b>	BARVA: ● BK ● ZN ● CN ● NI
	
Hmotnost: 0,045 kg	
Qty/box: 300 ks	

<b>W-8-30</b>	BARVA: ● BK ● ZN ● CN ● NI
	
Hmotnost: 0,07 kg	
Qty/box: 200 ks	

<b>W-8-45</b>	BARVA: ● BK ● ZN ● CN ● NI
	
Hmotnost: 0,072 kg	
Qty/box: 150 ks	

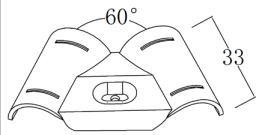
<b>W-8-60</b>	BARVA: ● BK ● ZN ● CN ● NI
	
Hmotnost: 0,075 kg	
Qty/box: 150 ks	

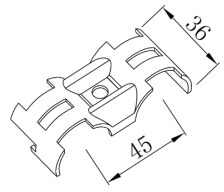
<b>W-9</b>	BARVA: ● BK ● ZN ● CN ● NI
	
Hmotnost: 0,07 kg	
Qty/box: 200 ks	

<b>W-9A</b>	BARVA: ● BK ● ZN ● CN ● NI
	
Hmotnost: 0,078 kg	
Qty/box: 200 ks	

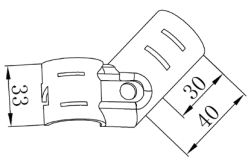
<b>W-10A</b>	BARVA: ● BK ● ZN ● CN ● NI
	
Hmotnost: 0,072 kg	
Qty/box: 200 ks	

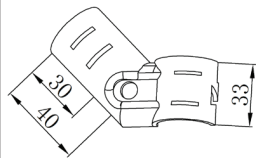
<b>W-10B</b>	BARVA: ● BK ● ZN ● CN ● NI
	
Hmotnost: 0,072 kg	
Qty/box: 200 ks	

## KOVOVÉ SPOJKY PRO 28 mm TRUBKOVÝ SPOJ

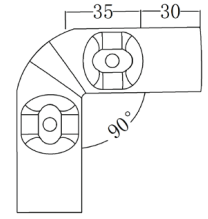
<b>W-11-90</b>	BARVA: ● BK ● ZN ● CN ● NI
	
Hmotnost: 0,1 kg	
Qty/box: 150 ks	

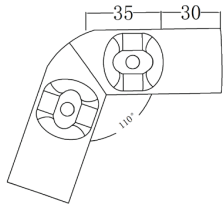
<b>W-11-110</b>	BARVA: ● BK ● ZN ● CN ● NI
	
Hmotnost: 0,11 kg	
Qty/box: 150 ks	

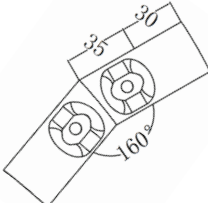
<b>W-11-160</b>	BARVA: ● BK ● ZN ● CN ● NI
	
Hmotnost: 0,11 kg	
Qty/box: 150 ks	

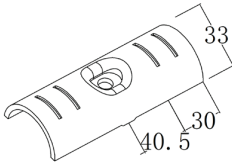
<b>W-11-180</b>	BARVA: ● BK ● ZN ● CN ● NI
	
Hmotnost: 0,1 kg	
Qty/box: 200 ks	

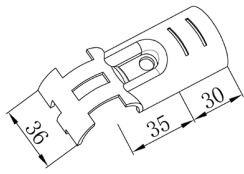
<b>W-12</b>	BARVA: ● BK ● ZN ● CN ● NI
	
Hmotnost: 0,07 kg	
Qty/box: 200 ks	

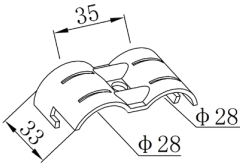
<b>W-13</b>	BARVA: ● BK ● ZN ● CN ● NI
	
Hmotnost: 0,055 kg	
Qty/box: 300 ks	

<b>W-13A</b>	BARVA: ● BK ● ZN ● CN ● NI
	
Hmotnost: 0,05 kg	
Qty/box: 300 ks	

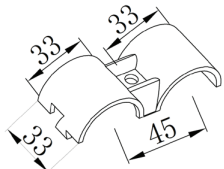
<b>W-13B</b>	BARVA: ● BK ● ZN ● CN ● NI
	
Hmotnost: 0,089 kg	
Qty/box: 200 ks	

<b>W-13C</b>	BARVA: ● BK ● ZN ● CN ● NI
	
Hmotnost: 0,089 kg	
Qty/box: 200 ks	

<b>W-14</b>	BARVA: ● BK ● ZN ● CN ● NI
	
Hmotnost: 0,65 kg	
Qty/box: 200 ks	

## KOVOVÉ SPOJKY PRO 28 mm TRUBKOVÝ SPOJ

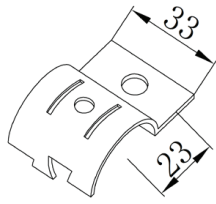
<b>W-15A</b>	BARVA: ● BK ● ZN ● CN ● NI
	
Hmotnost: 0,045 kg	
Qty/box: 400 ks	

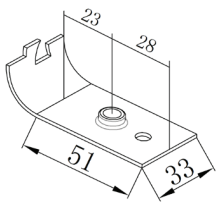
<b>W-15B</b>	BARVA: ● BK ● ZN ● CN ● NI
	
Hmotnost: 0,055 kg	
Qty/box: 400 ks	

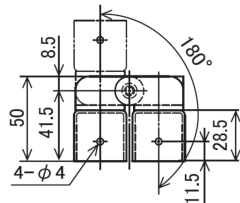
<b>W-16</b>	BARVA: ● BK ● ZN ● CN ● NI
	
Hmotnost: 0,055 kg	
Qty/box: 400 ks	

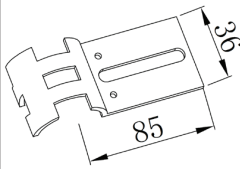
<b>W-17</b>	BARVA: ● BK ● ZN ● CN ● NI
	
Hmotnost: 0,065 kg	
Qty/box: 300 ks	

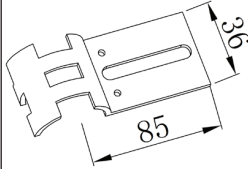
<b>W-17A</b>	BARVA: ● BK ● ZN ● CN ● NI
	
Hmotnost: 0,045 kg	
Qty/box: 200 ks	

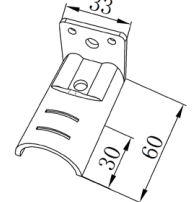
<b>W-18A</b>	BARVA: ● BK ● ZN ● CN ● NI
	
Hmotnost: 0,065 kg	
Qty/box: 150 ks	

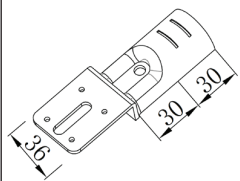
<b>W-18B</b>	BARVA: ● BK ● ZN ● CN ● NI
	
Hmotnost: 0,055 kg	
Qty/box: 200 ks	

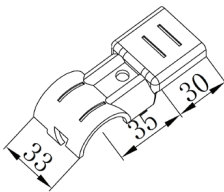
<b>W-19</b>	BARVA: ● BK ● ZN ● CN ● NI
	
Hmotnost: 0,085 kg	
Qty/box: 200 ks	

<b>W-20</b>	BARVA: ● BK ● ZN ● CN ● NI
	
Hmotnost: 0,122 kg	
Qty/box: 150 ks	

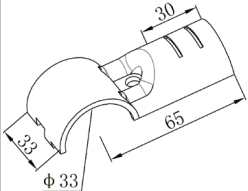
<b>W-21</b>	BARVA: ● BK ● ZN ● CN ● NI
	
Hmotnost: 0,082 kg	
Qty/box: 300 ks	

## KOVOVÉ SPOJKY PRO 28 mm TRUBKOVÝ SPOJ

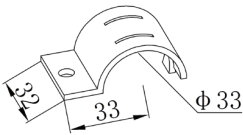
<b>W-22A</b>	BARVA: ● BK ● ZN ● CN ● NI
	
Hmotnost: 0,055 kg	
Qty/box: 300 ks	

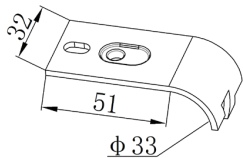
<b>W-22B</b>	BARVA: ● BK ● ZN ● CN ● NI
	
Hmotnost: 0,065 kg	
Qty/box: 300 ks	

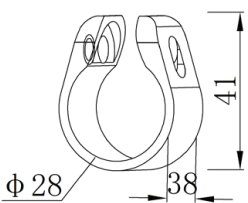
<b>W-23</b>	BARVA: ● BK ● ZN ● CN ● NI
	
Hmotnost: 0,082 kg	
Qty/box: 200 ks	

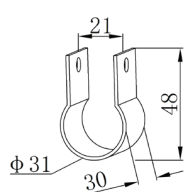
<b>W-24</b>	BARVA: ● BK ● ZN ● CN ● NI
	
Hmotnost: 0,035 kg	
Qty/box: 300 ks	

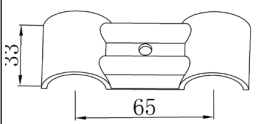
<b>W-25</b>	BARVA: ● BK ● ZN ● CN ● NI
	
Hmotnost: 0,098 kg	
Qty/box: 300 ks	



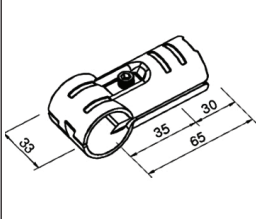

## KOVOVÉ SPOJKY PRO 28 mm TRUBKOVÝ SPOJ

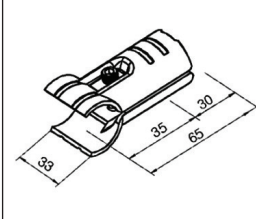
<b>WJ-1</b>	BARVA: ● BK ● ZN ● CN ● NI
	
W-1:2 ks M6*25:1 set	

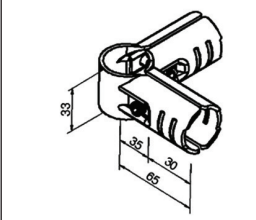
<b>WJ-1A</b>	BARVA: ● BK ● ZN ● CN ● NI
	
W-1A:2 ks M6*25:1 set	

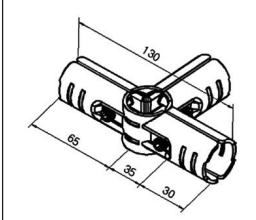
<b>WJ-2</b>	BARVA: ● BK ● ZN ● CN ● NI
	
W-2:1 ks W-3:1 ks M6*25:2 set	

<b>WJ-3</b>	BARVA: ● BK ● ZN ● CN ● NI
	
W-2:2 ks W-4:1 ks M6*25:3 set	

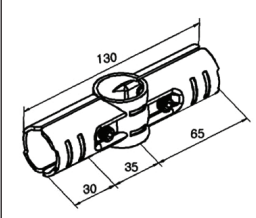
<b>WJ-4</b>	BARVA: ● BK ● ZN ● CN ● NI
	
W-4:2 ks M6*25:2 set	

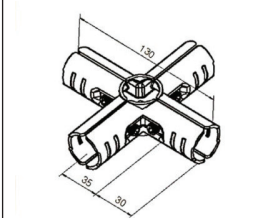
<b>WJ-5</b>	BARVA: ● BK ● ZN ● CN ● NI
	
W-2:4 ks M6*25:4 set	

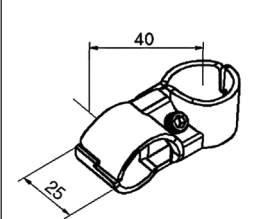
<b>WJ-6</b>	BARVA: ● BK ● ZN ● CN ● NI
	
W-7:2 ks M6*25:1 set	

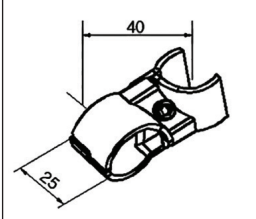
<b>WJ-6A</b>	BARVA: ● BK ● ZN ● CN ● NI
	
W-7A:2 ks M6*25:1 set	

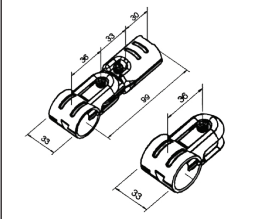
<b>WJ-7</b>	BARVA: ● BK ● ZN ● CN ● NI
	
W-5:2 ks W-6:2 ks M6*28:2 set	

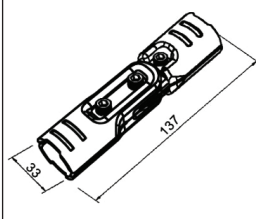
<b>WJ-7A</b>	BARVA: ● BK ● ZN ● CN ● NI
	
W-6A:4 ks M6*28:2 set	

## KOVOVÉ SPOJKY PRO 28 mm TRUBKOVÝ SPOJ

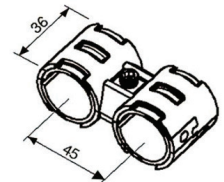
<b>WJ-8</b>	BARVA: ● BK ● ZN ● CN ● NI
	
W-9:2 ks WJP-6:2 ks M6*25:1 set	

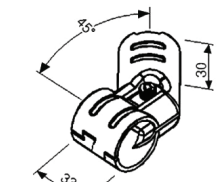
<b>WJ-9</b>	BARVA: ● BK ● ZN ● CN ● NI
	
W-10A:1 ks W-10B:1 ks M6*25:1 set	

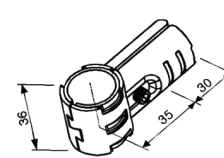
<b>WJ-10</b>	BARVA: ● BK ● ZN ● CN ● NI
	
W-12:2 ks WJP-6:2 ks M6*25:1 set	

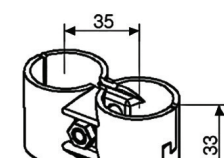
<b>WJ-11</b>	BARVA: ● BK ● ZN ● CN ● NI
	
W-13:2 ks M6*25:1 set	

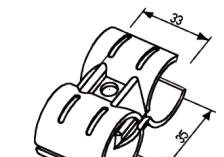
<b>WJ-11A</b>	BARVA: ● BK ● ZN ● CN ● NI
	
W-13A:2 ks M6*25:1 set	

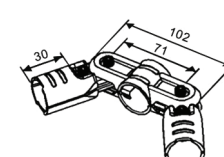
<b>WJ-12</b>	BARVA: ● BK ● ZN ● CN ● NI
	
W-6:4 ks W-14:2 ks M6*25:4 set	

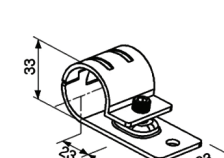
<b>WJ-13</b>	BARVA: ● BK ● ZN ● CN ● NI
	
W-15A:1 ks W-15B:1 ks M6*12:1 set	

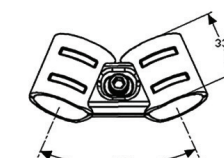
<b>WJ-14-30</b>	BARVA: ● BK ● ZN ● CN ● NI
	
W-8-30:2 ks M6*25:1 set	

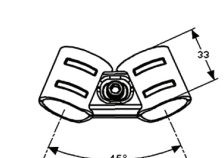
<b>WJ-14-45</b>	BARVA: ● BK ● ZN ● CN ● NI
	
W-8-45:2 ks M6*25:1 set	

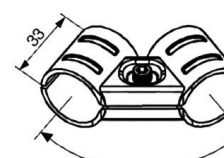
<b>WJ-14-60</b>	BARVA: ● BK ● ZN ● CN ● NI
	
W-8-60:2 ks M6*25:1 set	



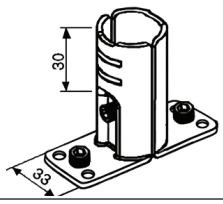

## KOVOVÉ SPOJKY PRO 28 mm TRUBKOVÝ SPOJ

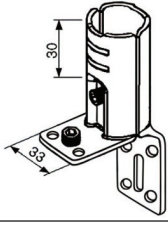
<b>WJ-15</b>	BARVA: ● BK ● ZN ● CN ● NI
	
	W-18A:2 ks M6*25:1 set

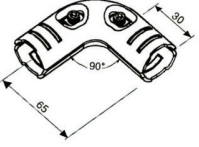
<b>WJ-15A</b>	BARVA: ● BK ● ZN ● CN ● NI
	
	W-18A:1 ks W-18B:1 ks M6*25:1 set

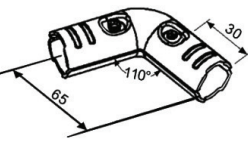
<b>WJ-16-90</b>	BARVA: ● BK ● ZN ● CN ● NI
	
	W-11-90:2 ks M6*25:2 set

<b>WJ-16-110</b>	BARVA: ● BK ● ZN ● CN ● NI
	
	W-11-110:2 ks M6*25:2 set

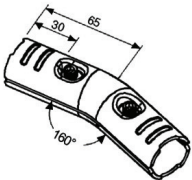
<b>WJ-16-160</b>	BARVA: ● BK ● ZN ● CN ● NI
	
	W-11-160:2 ks M6*25:2 set

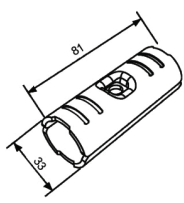
<b>WJ-16-180</b>	BARVA: ● BK ● ZN ● CN ● NI
	
	W-11-180:2 ks M6*25:1 set

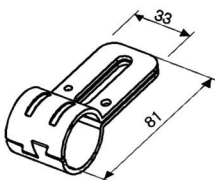
<b>WJ-17</b>	BARVA: ● BK ● ZN ● CN ● NI
	
	W-17:2 ks M6*25:1 set

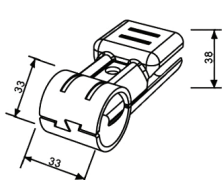
<b>WJ-18</b>	BARVA: ● BK ● ZN ● CN ● NI
	
	W-19:2 ks M6*25:1 set

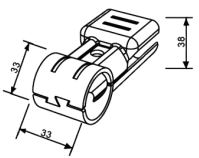
<b>WJ-18A</b>	BARVA: ● BK ● ZN ● CN ● NI
	
	W-19:1 ks W-1:1 ks M6*25:1 set

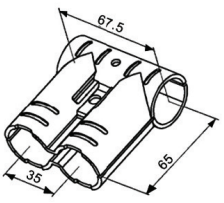
<b>WJ-19</b>	BARVA: ● BK ● ZN ● CN ● NI
	
	W-20:2 ks M6*25:1 set

## KOVOVÉ SPOJKY PRO 28 mm TRUBKOVÝ SPOJ

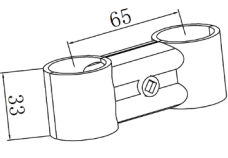
<b>WJ-20</b>	BARVA: ● BK ● ZN ● CN ● NI
	
W-25:2 ks M6*25:1 set	

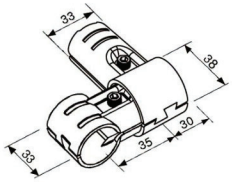
<b>WJ-21</b>	BARVA: ● BK ● ZN ● CN ● NI
	
W-21:2 ks M6*25:1 set	

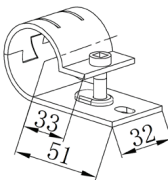
<b>WJ-22</b>	BARVA: ● BK ● ZN ● CN ● NI
	
W-22A:1 ks W-22B:1 ks M6*25:1 set	

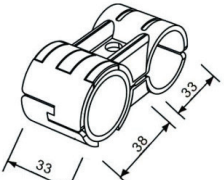
<b>WJ-23</b>	BARVA: ● BK ● ZN ● CN ● NI
	
W-9A:2 ks WJP-06:1 ks M6*25:1 set	

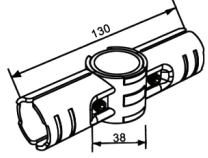
<b>WJ-24</b>	BARVA: ● BK ● ZN ● CN ● NI
	
W-4B:2 ks WJP-06:1 ks M6*25:2 set	

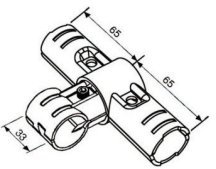
<b>WJ-25</b>	BARVA: ● BK ● ZN ● CN ● NI
	
W-4A:2 ks M6*25:2 set	

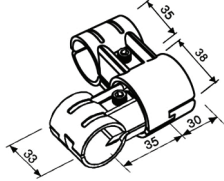
<b>WJ-26</b>	BARVA: ● BK ● ZN ● CN ● NI
	
W-13B:2 set M6*25:1 set	

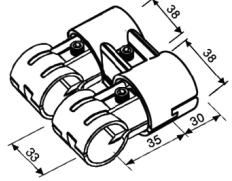
<b>WJ-27</b>	BARVA: ● BK ● ZN ● CN ● NI
	
W-19:2 ks M6*25:1 set	

## PODROBNÝ POPIS POTAŽENÝCH TRUBEK Ø = 28,6 mm

### Standardní barvy potažených trubek





	IV : Ivory
	WH : White
	SB : Sky Blue
	DB : Dark Blue
	RE : Red
	GR : Green
	YE : Yellow
	BE : Beige
	LG : Lite Gray
	DG : Dark Gray
	BK : Black
	EBK : ESD Black
	ESD Gray
	ESD Ivory

### T = tloušťka

10 = T1,0
20 = T2,0

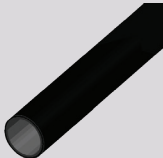
## POTAŽENÉ TRUBKY - Ø = 28,6 mm

číslo dílu	rozměr	hmotnost	kapacita	MOQ	zařazení	standardní délka	barva	obrázek
	(mm)	(g/m)	kg/m	(ks)		(mm)		
CP-3010	Ø 28,6 * 1,0	700	100	⊙	potažená trubka	4000	IV WH SB DB RE GR YE BE LG BK	
CP-3020	Ø 28,6 * 2,0	1300	200	500				
CP-3010ESD	Ø 28,6 * 1,0	700	100	⊙	potažená trubka	4000	EBK ESD šedá	
CP-3020ESD	Ø 28,6 * 2,0	1300	200	500				
SPS-3010	Ø 28,6 * 1,0	670	90	500	SUS439 SUS201 SUS304 nerez	4000	stříbrná	

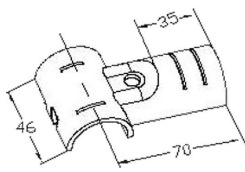

## KOVOVÉ SPOJKY PRO 28,6 mm TRUBKOVÝ SPOJ

<b>L-1</b>	BARVA: ● BK ● ZN ● CN ● NI
	
Hmotnost: 0,07 kg	
Qty/box: 300 ks	

<b>L-2</b>	BARVA: ● BK ● ZN ● CN ● NI
	
Hmotnost: 0,07 kg	
Qty/box: 300 ks	

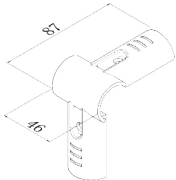
<b>L-3</b>	BARVA: ● BK ● ZN ● CN ● NI
	
Hmotnost: 0,07 kg	
Qty/box: 300 ks	

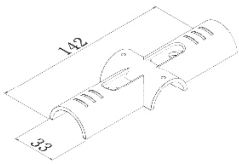
<b>L-4</b>	BARVA: ● BK ● ZN ● CN ● NI
	
Hmotnost: 0,07 kg	
Qty/box: 300 ks	

<b>S-1</b>	BARVA: ● BK ● ZN ● CN ● NI
	
Hmotnost: 0,07 kg	
Qty/box: 300 ks	

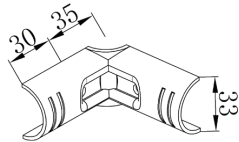
<b>S-2</b>	BARVA: ● BK ● ZN ● CN ● NI
	
Hmotnost: 0,091 kg	
Qty/box: 200 ks	

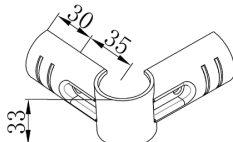
<b>S-3</b>	BARVA: ● BK ● ZN ● CN ● NI
	
Hmotnost: 0,125 kg	
Qty/box: 100 ks	

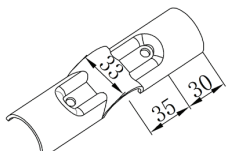
<b>S-4</b>	BARVA: ● BK ● ZN ● CN ● NI
	
Hmotnost: 0,11 kg	
Qty/box: 200 ks	

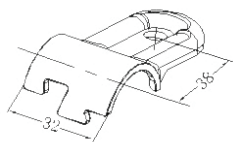
<b>S-5</b>	BARVA: ● BK ● ZN ● CN ● NI
	
Hmotnost: 0,07 kg	
Qty/box: 300 ks	

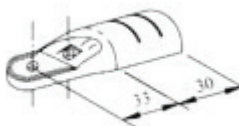
<b>S-6</b>	BARVA: ● BK ● ZN ● CN ● NI
	
Hmotnost: 0,07 kg	
Qty/box: 300 ks	

## KOVOVÉ SPOJKY PRO 28,6 mm TRUBKOVÝ SPOJ

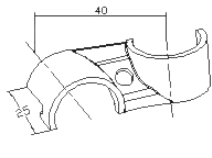
<b>S-7</b>	BARVA: ● BK ● ZN ● CN ● NI
	
Hmotnost: 0,07 kg	
Qty/box: 300 ks	

<b>S-8-45</b>	BARVA: ● BK ● ZN ● CN ● NI
	
Hmotnost: 0,07 kg	
Qty/box: 300 ks	

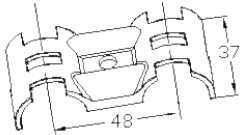
<b>S-9</b>	BARVA: ● BK ● ZN ● CN ● NI
	
Hmotnost: 0,07 kg	
Qty/box: 300 ks	

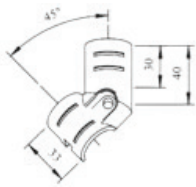
<b>S-10A</b>	BARVA: ● BK ● ZN ● CN ● NI
	
Hmotnost: 0,07 kg	
Qty/box: 300 ks	

<b>S-10B</b>	BARVA: ● BK ● ZN ● CN ● NI
	
Hmotnost: 0,07 kg	
Qty/box: 300 ks	

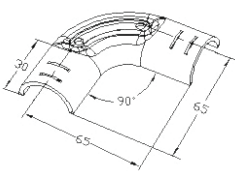
<b>S-11-90</b>	BARVA: ● BK ● ZN ● CN ● NI
	
Hmotnost: 0,07 kg	
Qty/box: 300 ks	

<b>S-13</b>	BARVA: ● BK ● ZN ● CN ● NI
	
Hmotnost: 0,07 kg	
Qty/box: 300 ks	

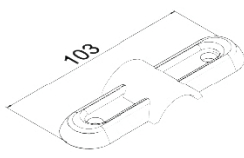
<b>S-14</b>	BARVA: ● BK ● ZN ● CN ● NI
	
Hmotnost: 0,07 kg	
Qty/box: 300 ks	



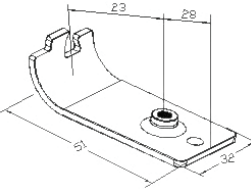



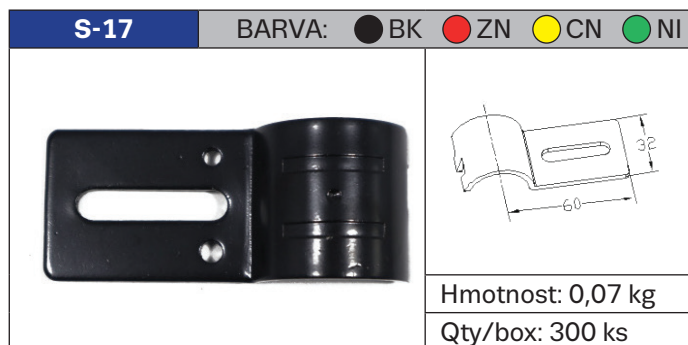

<b>S-15A</b>	BARVA: ● BK ● ZN ● CN ● NI
	
Hmotnost: 0,07 kg	
Qty/box: 300 ks	

<b>S-15B</b>	BARVA: ● BK ● ZN ● CN ● NI
	
Hmotnost: 0,07 kg	
Qty/box: 300 ks	

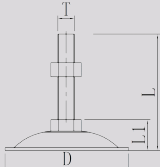
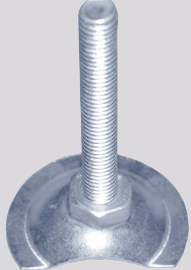
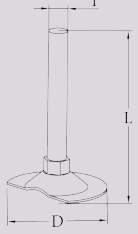
## KOVOVÉ SPOJKY PRO 28,6 mm TRUBKOVÝ SPOJ

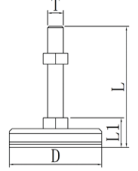

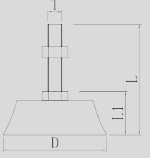
## PATKY

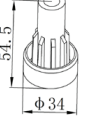
Série	kód	D/ průměr	výška	Vnější průměr šroubu	obrázek	výkres
		(mm)	(mm)			
Malý typ	SPB28E-10 (SPB30E-10)	28 (30)	/	M10		SPB28E = 28MMTUBE  SPB30E = 28.6MMTUBE
	SPB28E-12 (SPB30E-12)	28 (30)	/	M12		
	SPB28E-1/2 (SPB30E-1/2)	28 (30)	/	1/2"		
	SPB28E- 3/8(SPB30E-3/8)	28 (30)	/	3/8"		
	ADP3-34	34	/	/		
	ADP3-52	52	/	/		
Normální typ	AD3-3850-10	38	50	M10		
	AD3-3850- 3/8	38	50	3/8"		
	AD3-3880-10	38	80	M10		
	AD3-3880- 3/8	38	80	3/8"		
	AD3-5050-10	50	50	M10		
	AD3-5050- 3/8	50	50	3/8"		
	AD3-50100-12	50	100	M12		
	AD3-50100- 1/2	50	100	1/2"		
	AD3-50100- 5/8	50	100	5/8"		
	AD4-3850-10	38	50	M10		
	AD4-3850- 3/8	38	50	3/8"		
	AD4-3880-10	38	80	M10		
	AD4-3880- 3/8	38	80	3/8"		
	AD4-5050-10	50	50	M10		
	AD4-5050- 3/8	50	50	3/8"		
	AD4-50100-12	50	100	M12		
	AD4-50100- 1/2	50	100	1/2"		
	AD4-50100- 5/8	50	100	5/8"		
Gumový typ ESD černý	AD5-3850-10	38	50	M10		
	AD5-3880-10	38	80	M10		
	AD5-38100-10	38	100	M10		
	AD5-5080-10	50	80	M10		
	AD5-3880-12	38	100	M12		
Gumová podložka ESD černý	AD6-3260-10	32	60	M10		
	AD6-3560-10	35	60	M10		
	AD6-5460-10	54	60	M10		
	AD6-5460-12	54	60	M12		
Nastavitelné příslušenství	WA-AD5-10	/	/	M10		
	WA-AD5-12	/	/	M12		
	WA-AD5- 1/2	/	/	1/2"		
	WA-AD5- 3/8	/	/	3/8"		



## POUZDROVÁ MATICE

Série	kód	Aplikace	Vnější průměr šroubu	QTY	barva	obrázek
Nerezová trubka	SPB2807-10 (SPB3007-10)	28*0.7 (28.6*0.7)	M10	200	zinek	
	SPB2807-12 (SPB3007-12)	28*0.7 (28.6*0.7)	M12	200	zinek	
Nerezová trubka	SPB2810- 10 (SPB3010-10)	28*1.0 (28.6*1.0)	M10	200	zinek	
	SPB2810- 12 (SPB3010-12)	28*1.0 (28.6*1.0)	M12	200	zinek	
Nerezová trubka	SPB2812- 10 (SPB3012-10)	28*1.2 (28.6*1.2)	M10	200	zinek	
	SPB2812- 12 (SPB3012-12)	28*1.2 (28.6*1.2)	M12	200	zinek	
Potažená trubka	CPB2807-10 (CPB3007-10)	28*0.7 (28.6*0.7)	M10	200	zinek	
	CPB2807-12 (CPB3007-12)	28*0.7 (28.6*0.7)	M12	200	zinek	
Potažená trubka	CPB2810- 10 (CPB3010-10)	28*1.0 (28.6*1.0)	M10	200	zinek	
	CPB2810- 12 (CPB3010-12)	28*1.0 (28.6*1.0)	M12	200	zinek	
Potažená trubka	CPB2812- 10 (CPB3012-10)	28*1.2 (28.6*1.2)	M10	200	zinek	
	CPB2812- 12 (CPB3012-12)	28*1.2 (28.6*1.2)	M12	200	zinek	
Potažená trubka	CPB2815- 10 (CPB3015-10)	28*1.5 (28.6*1.5)	M10	200	zinek	
	CPB2815- 12 (CPB3015-12)	28*1.5 (28.6*1.5)	M12	200	zinek	
Potažená trubka	CPB2820- 10 (CPB3020-10)	28*2.0 (28.6*2.0)	M10	200	zinek	
	CPB2820- 12 (CPB3020-12)	28*2.0 (28.6*2.0)	M12	200	zinek	

## PLASTOVÉ LIŠTY

Série	kód	výška	šířka	obrázek	výkres
		(mm)	(mm)		
L - typ	JP-L1	35	35		
	JP-L2	35	40		
	JP-L3	30	50		
	JP-L4	50	60		
	JP-L5	50	75		
	JP-L6	50	100		
	JP-L7	80	90		
T - typ	JP-T1	50	100		
	JP-T2	100	60		

## PLASTOVÉ KRYTKY NA NOHY

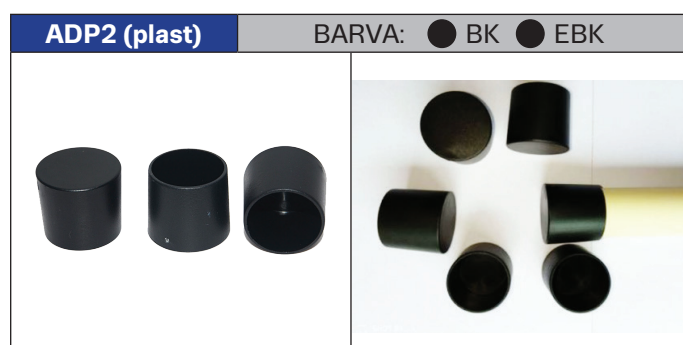

## ZÁSLEPKY



Pouze potažené trubky



Pouze trubky z nerezové oceli

## ŠROUBY A MATICE

Kód	položka	specifikace	barva	použití	obrázek
TN06B	T-MATICE	M6	ČERNÁ	KOVOVÝ SPOJ	
TN06W		M6	ZINEK		
NN08W	SAMOZAJIŠŤOVACÍ MATICE	M8	ZINEK	M8 ŠROUB	
N08W	MATICE	M8	ZINEK	M8 ŠROUB	
PW08W	PODLOŽKA	M8	ZINEK	M8 ŠROUB	
B0610B	M6 x 10	M6	ČERNÁ	KOVOVÝ SPOJ	
B0610W	M6 x 10	M6	ZINEK		
B0625B	M6 x 25	M6	ČERNÁ		
B0625W	M6 x 25	M6	ZINEK		
B0628B	M6 x 28	M6	ČERNÁ		
B0628W	M6 x 28	M6	ZINEK		
B0630B	M6 x 30	M6	ČERNÁ		
B0630W	M6 x 30	M6	ZINEK		
B0835W	M8 x 35	M8	BÍLÁ	KOLEČKO	
B0840W	M8 x 40	M8	BÍLÁ		
B0850W	M8 x 50	M8	BÍLÁ		
BH0625B	M6 x 25	M6	ČERNÁ	KOVOVÝ SPOJ	
BH0625W	M6 x 25	M6	ZINEK		
BH0628B	M6 x 28	M6	ČERNÁ		
BH0628W	M6 x 28	M6	ZINEK		
BH0630B	M6 x 30	M6	ČERNÁ		
BH0630W	M6 x 30	M6	ZINEK		

# APLIKACE

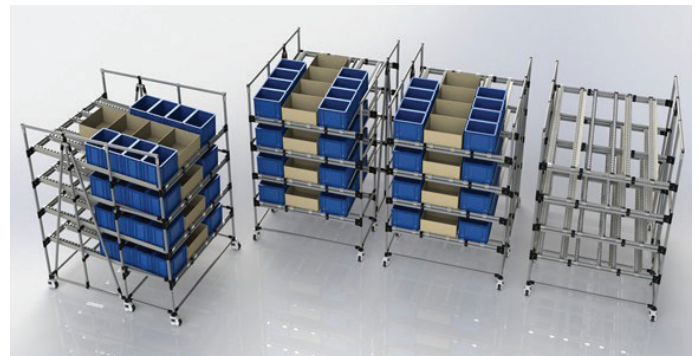
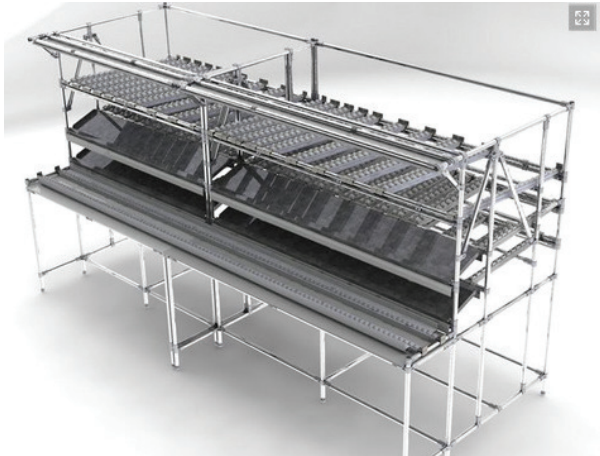

## TECHNICKÉ SPECIFIKACE

### PEVNOST OHYBU VÁLEČKOVÉ DRÁHY

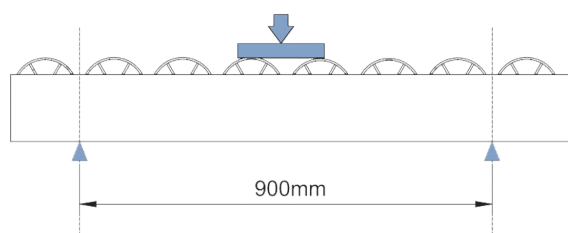

#### Zkušební podmínky

1. testovací rychlost: 5mm / min
2. teplota : 23°C

\* kgf - 1 kilogram force = 9.806 N

Model	Zatížení (kgf)
Serie 35	80
Serie 40	150
Serie 60	100
Serie 70	200
Serie 85	300

### PEVNOST V TLAKU NA KOLO

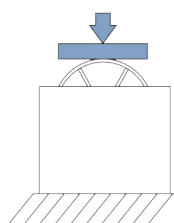

#### Zkušební podmínky

1. testovací rychlost: 5mm / min
2. teplota : 23°C

Model	Zatížení (kgf)
Serie 35	100
Serie 40	150
Serie 60	200
Serie 70	200
Serie 85	300

### DOPORUČENÝ ÚHEL SKLONU

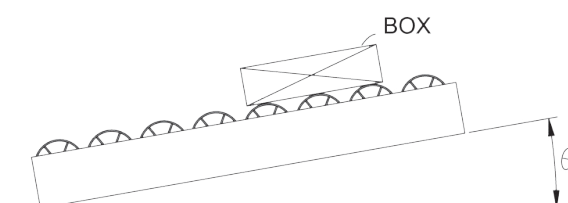

#### Zkušební podmínky

1. hmotnost boxu: 0,75 kg
2. teplota : 23°C

Model	Úhel (θ)
Serie 35	1,45
Serie 40	1,66
Serie 60	1,62
Serie 70	1,58
Serie 85	1,38

### PEVNOST OHYBU TRUBEK

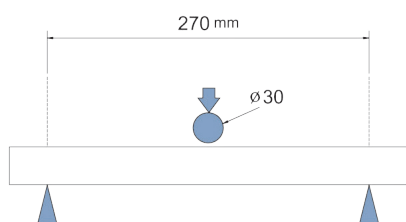

#### Zkušební podmínky

1. testovací rychlost: 5mm / min
2. teplota : 23°C

Vzdálenost podpěr (mm)

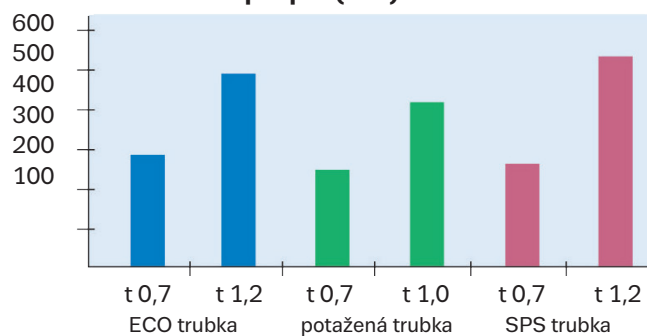

Spec. trubky	ECO trubka	Potažená trubka	SPS trubka nerez
Ø 28 x t 0,7	290	260	265
Ø 28 x t 1,0	-	420	-
Ø 28 x t 1,2	480		540

## TECHNICKÉ SPECIFIKACE

### SVĚRNÁ SÍLA

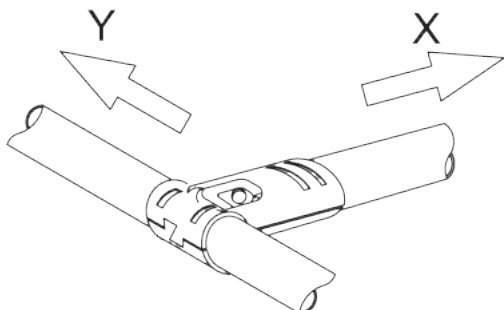

#### Zkušební podmínky

1. testovací rychlost: 5mm / min
2. teplota : 23 °C

Klasifikace	Potažená trubka		Nerezová ocelová trubka	
	Ø 28 x t 0,7	Ø 28 x t 1,0	Ø 28 x t 0,7	Ø 28 x t 1,2
Směr: X	více než 80 kg	více než 80 kg	více než 80 kg	více než 80 kg
Směr: Y	více než 80 kg	více než 80 kg	více než 80 kg	více než 80 kg

### STANOVENÍ STANDARDNÍ DÉLKY TRUBEK

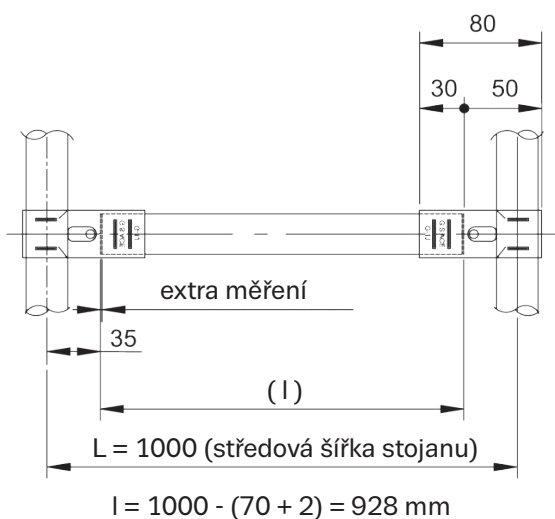

#### Pouzdro Ø28 mm

1000 mm	středové měření (L)
-70 mm	délka trubky vnitřní spoj (35 mm x2)
-2 mm	extra měření (2 mm ~ 5 mm)
928 mm	délka trubky (l)





 **ALUTEC KK**

ALUTEC KK  
Zálužská 120  
250 88 Čelákovice - Záluží  
Česká republika

+420 326 996 110  
aluteckk@aluteckk.cz

[WWW.ALUTECKK.CZ](http://WWW.ALUTECKK.CZ)

